



Keithley Instruments, Inc.
 28775 Aurora Road
 Cleveland, Ohio 44139
 (440) 248-0400
 www.keithley.com

Model 2600-TRIAX SMU Connector User's Guide

Overview

WARNING The procedures contained in this User's Guide are intended for use by qualified service personnel only. Do not perform these procedures unless qualified to do so. Failure to recognize and observe normal safety precautions could result in personal injury or death.

Figure 1
 Model 2600-TRIAX SMU Connector

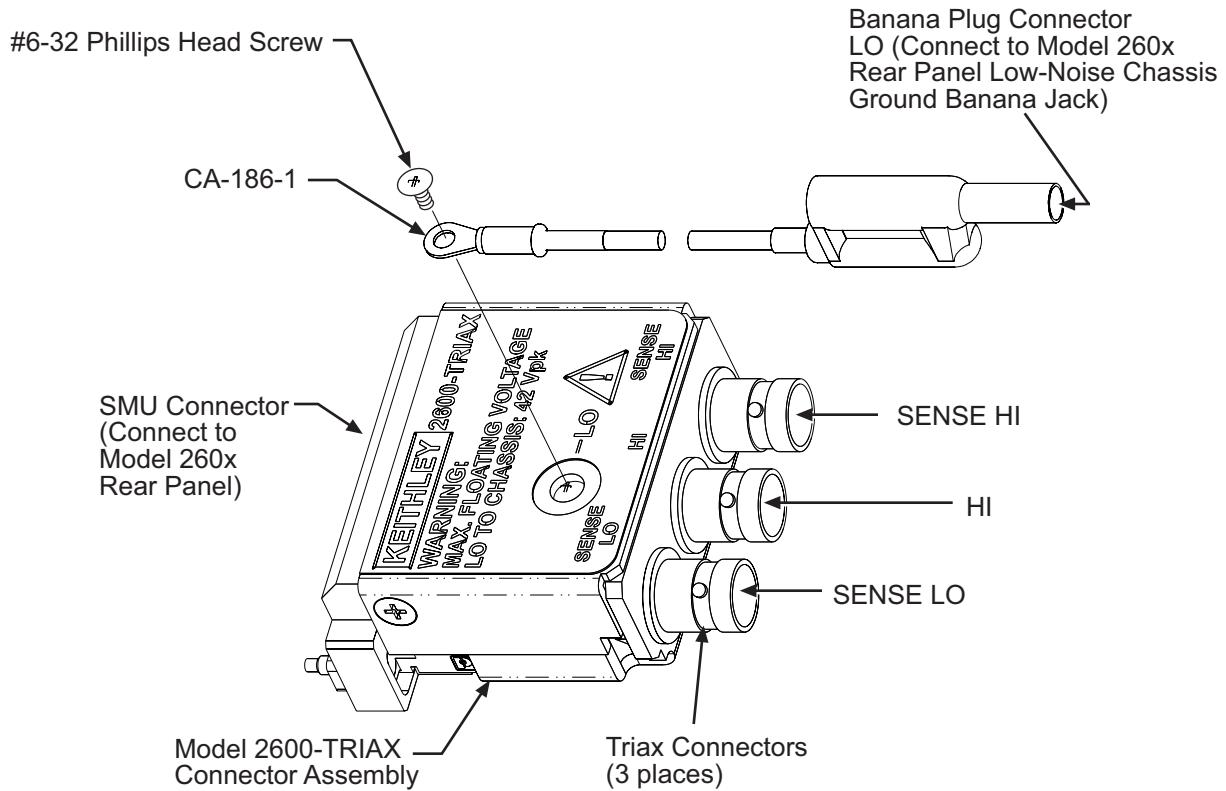

The Model 2600-TRIAX Connector assembly (Figure 1) provides pathways from an SMU terminal block located on the Model 260x rear panel to three triax connectors. The triax connectors' pathways are shown in Table 1 and Figure 2, as well as a low-noise chassis ground banana jack that can be used as a common signal ground point for Input/Output LOs (through cable Model CA-186-1). This low-noise signal ground banana jack is connected to the chassis through a Frequency Variable Resistor (FVR). For additional connection information, refer to the Model 260x SMU Reference Manual (Document Number 260x-901-01).

Table 1
Connector pathway description

Connector	Outer Shield	Inner Conductor	Inner Shield
TRIAx SENSE HI	LO SMU Pin 1	Sense HI SMU Pin 8	Guard SMU Pin: 3, 5, 6, 7
TRIAx HI		HI SMU Pin 4	
TRIAx SENSE LO		Sense LO SMU Pin 2	LO
Screw-Lug LO	NA	LO SMU Pin 1*	NA

* LO will need to be connected externally using cable Model CA-186-1. Install the cable between the Model 2600-TRIAx (secure using the existing #6-32 Phillips Head screw) and the other end to the Low-Noise Chassis Ground banana jack (located on the Model 260x rear panel).

Figure 2
Connector Schematic

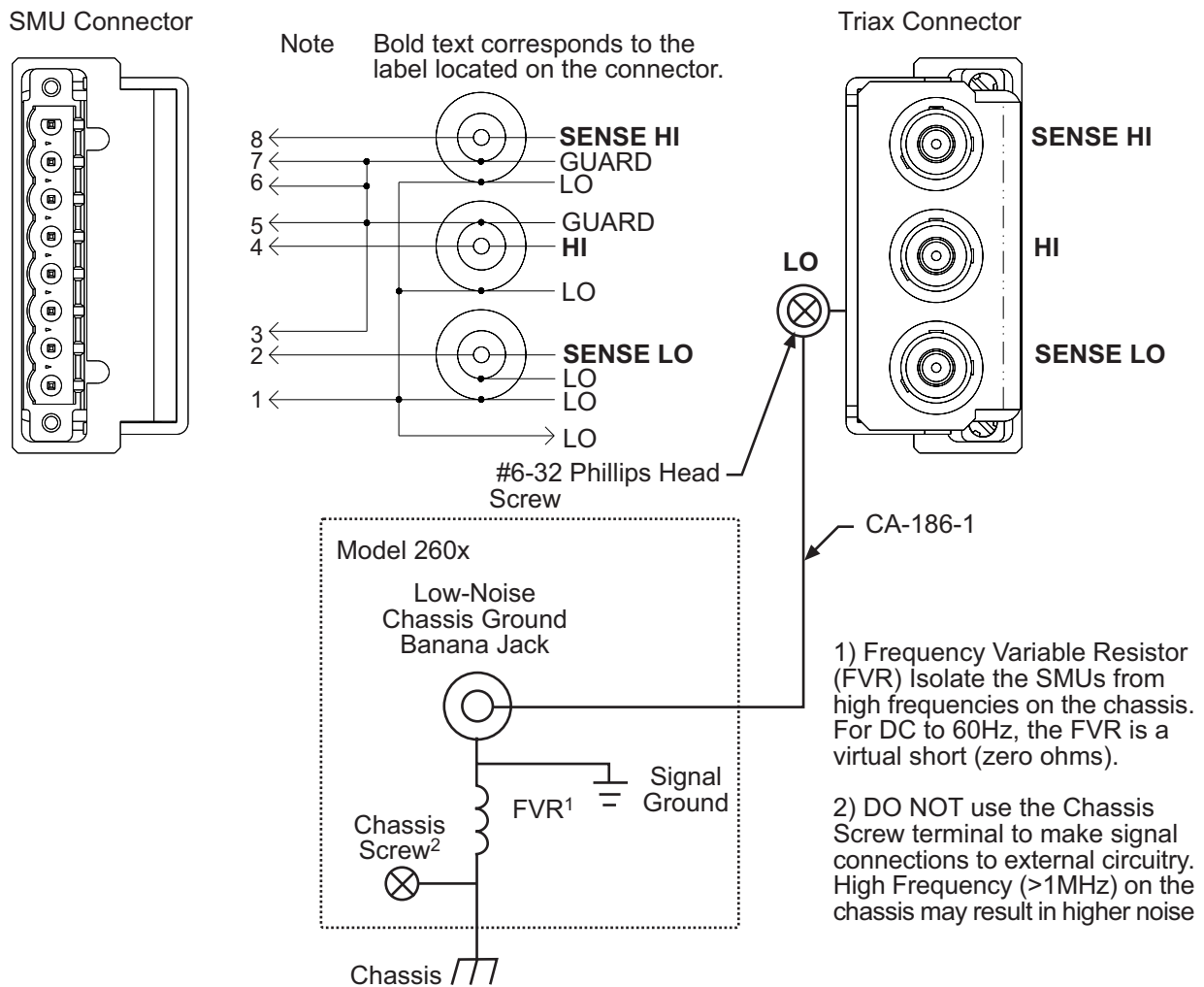

General definitions

The types of product users are:

Responsible body is the individual or group responsible for the use and maintenance of equipment, and for ensuring that operators are adequately trained.

Operators use the product for its intended function. They must be trained in electrical safety procedures and proper use of the instrument. They must be protected from electric shock and contact with hazardous live circuits.

Maintenance personnel perform routine procedures on the product to keep it operating, for example, setting the line voltage or replacing consumable materials. Maintenance procedures are described in the manual. The procedures explicitly state if the operator may perform them. Otherwise, they should be performed only by service personnel.

Service personnel are trained to work on live circuits, and perform safe installations and repairs of products. Only properly trained service personnel may perform installation and service procedures.

If  is present, connect it to safety earth ground using the wire recommended in the user documentation.

The  symbol on an instrument indicates that the user should refer to the operating instructions located in the manual.

The  symbol on an instrument shows that it can source or measure 1000 volts or more, including the combined effect of normal and common mode voltages. Use standard safety precautions to avoid personal contact with these voltages.

The  symbol indicates a connection terminal to the equipment frame.

The **WARNING** heading in a manual explains dangers that might result in personal injury or death. Always read the associated information very carefully before performing the indicated procedure.

The **CAUTION** heading in a manual explains hazards that could damage the instrument. Such damage may invalidate the warranty.

Operation

WARNING There can be exposure to hazardous voltages and risk of electric shock when this assembly is connected—do not touch connectors.

If this connector is used with an instrument capable of sourcing voltages greater than 42V, then the user must provide an additional safety barrier to prevent the possibility of electrical shock.

No interlock features are provided by this device—properly make all connections before energizing instrumentation connected to this assembly.

Maximum floating voltage LO to chassis when using this device is 42V.

CAUTION The current leakage specifications depend upon a clean fixture. Avoid contamination that could cause degraded performance and increase current leakages beyond specified limits.

NOTE Keep in mind that the chassis of the Model 260x should never be used as a ground point for signal connections. Instead, use the low-noise chassis ground banana jack and cable Model CA-186-1. High frequencies present on the chassis of the Model 260x may result in higher noise—the chassis should only be used as a safety shield. Use the chassis screw for connections to the chassis of the Model 260x.

Handling and cleaning

When making or breaking connections, use care not to touch the connector. This will help avoid contamination from body oils or other foreign matter. The current leakage specifications depend upon a clean fixture. Contamination could cause degraded performance which might increase current leakages beyond specified limits.

Handling

Observe the following precautions when handling components:

- Wear cotton gloves.
- Avoid unnecessary touching of the connectors.

Cleaning

To clean connectors:

- Swab the connector with methanol.
- Quickly dry the test connector after cleaning by directing dry nitrogen gas.
- After cleaning, allow the connector to dry in a 50°C, low-humidity environment for one hour.